

**WHEELED EXCAVATORS
WX188 | WX218**

CASE
CONSTRUCTION



**MISSION
ACCOMPLISHED**

www.casece.com

**EXPERTS FOR THE REAL WORLD
SINCE 1842**

WHEELED EXCAVATORS



THE “8 SERIES”

POWER AND CONTROL

The WX wheeled excavators are designed to deliver a maximum of productivity and precision.

The extra powerful hydraulics are managed by the Case Intelligent Hydraulic System (CIHS) control, which offers a single CPU for improved controllability and simplified diagnostics. The Case wheeled excavators use a 3-pump hydraulic system, with one pump dedicated to the slew function. This provides continuous movement and allows the operator to multi-function the controls for smooth, productive digging performance.

Case wheel excavators are equipped with Case Intelligent Swing system (CIS) allowing the operator to adjust the upperstructure slew speed to suit to all working site conditions.

Two new working modes, easily switchable on the joystick, have been implemented to better adapt the machine behaviour to specific tasks: STANDARD MODE suited for general applications and precision grading with maximum fuel savings; POWER MODE for a maximised production and faster cycles.

The Automatic Powerboost function delivers maximum performance for heavy breakout and lifting operations. The Power Limit Control feature monitors the engine and hydraulic pumps to optimise power output.

SUPERIOR VERSATILITY

The flow and pressure to the attachments is easy to adjust and up to 12 settings for different attachments can be memorised.



WHEELED EXCAVATORS



POWERTRAIN

Our WX excavators drive through a fully automatic hydrostatic powershift transmission and heavy duty ZF axles, providing fast travel speed between working sites and excellent traction. An improved orbitrol steering system delivers effortless and precise control. A larger steering angle makes it even easier to move in confined areas. With a creep speed function and high ground clearance, the machines are also capable of tackling the toughest of site conditions.

Excellent drawbar pull is a feature of all three machines and the axles have an auto-locking feature for maximum stability when working without stabilisers. Multi-disc wet brakes and axle oil change intervals of 2,000 hours will reduce your customers' ownership and operating costs.

TOTAL STABILITY

The new WX design leads to an outstanding stability even on tires only.

Our wheeled excavators have always boasted a robust design and sturdy build quality. These new WX models are no exception, with a strong chassis providing the option of a dozer blade, the dozer blade and stabilisers, or stabilisers front and rear for total balance and a stable working platform. The dozer blade with parallel kinematics is made extra-robust in curved design for best material retention.

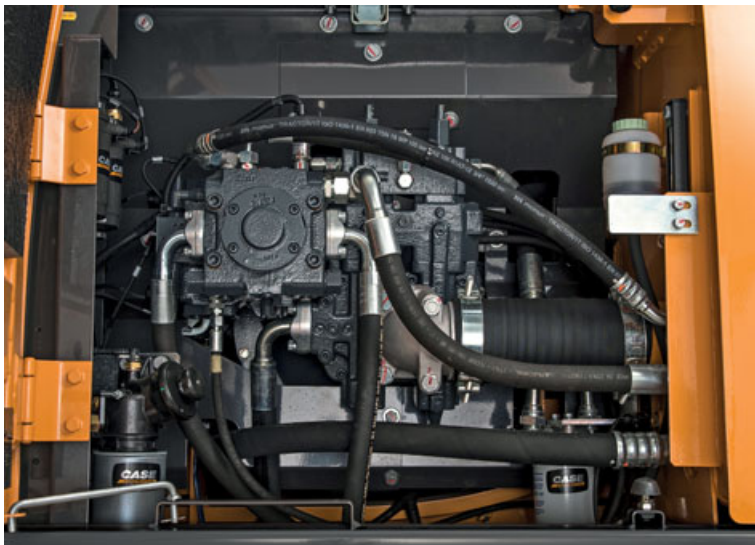

EASY MAINTENANCE

Big and wide-opening hoods provide easy access to all service points. Maintenance operations are quick and easy with the grouped, easily accessible greasing points, and easy to reach filters at the rear of the machine. The extended greasing intervals for the attachment (up to 500 hours) maximise uptime and lower operating costs.



RADIATOR LAYOUT

The side-by-side radiator layout results in an extremely reliable cooling performance and makes it easier to clean them. A front net keeps dust away from the radiators, lengthening the interval between cleanings.

SAFETY

SAFE ATTACHMENT OPERATION

Boom cylinders feature safety valves as standard. For added safety, a complete object handling kit (safety valves on dipper, loading hook, overload warning) and a heavy-duty holder for grabs are available as options.

ROPS/FOPS CAB

The reinforced structure of the cab is ROPS and FOPS certified.



WHEELED EXCAVATORS





FIRST-CLASS COMFORT

The inclination of the steering column is continuously adjustable to fit the operator's best working position; the controls are individually adjustable to match their preferences; the adjustable air suspended and heated seat combined with the ergonomic design of armrests and foot pedals provide the best possible workstation.

The tinted safety glass, sun blinds and transparent rain protection above the front window provide comfortable working conditions, while the automatic air conditioning maintains a comfortable in-cab climate for more productive work.

A hot and cool box, plenty of storage compartments, a radio with USB support, a microphone for handsfree conversation, a front aux. port and a 12V auxiliary socket complete the operator's comfortable workstation.

EASY TO OPERATE

The controls layout is designed to minimise fatigue, with all travel functions and switches easily accessible and grouped on the steering column. The machine's information is easy to access and understand on the in-cab monitor, so the operator can focus on the job. A new engine speed and working mode selection dial makes it easy for the operator to set the machine up in any working situation. The dial delivers low idle speed, two lifting modes, and three Eco working modes. It also provides access to the Heavy Mode for maximum digging performance. The new levelling mode can be easily activated in Eco or Heavy mode by simply pressing a switch on the right hand joystick. The blade and each of the stabilizers are proportionally operated. Each of the stabilizers can be easily activated by switches.

ALL-ROUND VISIBILITY

Large glazed surfaces, safety tinted glass, one-piece right-hand side window and large roof window provide superior visibility all around. Standard working lights on the boom and cab front add to the excellent visibility.

The standard rear view camera further enhances visibility to the rear.





THE SCIENCE BIT

The Case SiteWatch telematics system uses a high-tech control unit mounted on each machine to collate information from that machine and from GPS satellites. This data is then sent wirelessly through the mobile communication networks to the Case Telematics Web Portal.



SiteWatch: centralised fleet control benefits at your fingertips

Measure your true asset availability and optimise it

- Eliminate the “phantom fleet”: SiteWatch allows to identify spare units or under loaded machines on each site.
- Become able to reallocate units where they are more needed.
- Forward Maintenance Planning is easier since the actualised working hours are always available.
- Extend the benefits of SiteWatch to the rest of your fleet: SiteWatch can be installed on the units of other brands as well.

Challenge your Total Cost of Ownership!

- Being able to compare the fuel usage of different machine types will allow you choose the right equipment.
- Save on transport costs with planned and grouped maintenance tasks.
- Peace of mind, optimised uptime and lower repair costs: with preventive maintenance you can for example be alerted if the engine needs to be serviced and avoid a disruptive breakdown.
- Be able to compare your asset Return On Investment on different sites.
- Your equipment is used only during working hours. You can set up alerts so that you know if it is in use during the weekend or at night.
- Integrate with the programmed maintenance package, so that you can be sure every machine is at the right place at the right time.

More Safety, Lower Insurance Premium

- Keep thieves away: dissuade them from attacking your asset because it is geo-localised. SiteWatch is hidden so that thieves can't find it quickly.
- Your fleet is used only where you decide. You can define a virtual fence and receive an email when a machine exits that perimeter.

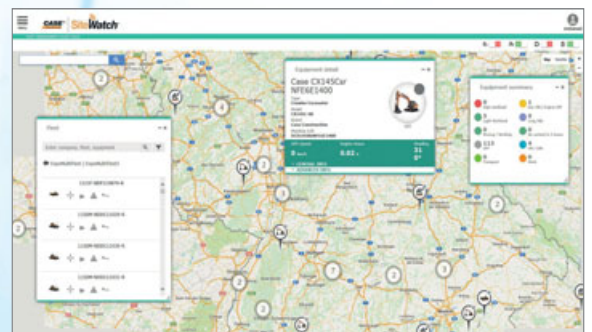

STANDARD EQUIPMENT

Latest generation FPT Stage III / Tier 3 diesel engine
Direct injection with turbo charger and charge air cooling
Air filter with safety cartridge
Engine filters (oil, fuel and water separator) in remote position
Auto-idling system
Cold starting equipment (-25°C)
Pump management system by power limit control
Electrohydraulic servo control
3-pumps hydraulic system with two service pumps and separate swing pump
Auto Power Boost system
8 selectable power stages with permanent Power Boost in lift stages
Automatic power increase in road travel mode
Automatic battery main switch (coupled to ignition key)
Electronic immobiliser (PIN code)
12 V electrical auxiliary supply in cab
Swing hydrostatic braking
Automatic / permanent swing brake modes
Swing drive with low-wearing disc brake
CIS (CASE intelligent system) : Adjustable swing acceleration (power) and deceleration (brake)
Cab according ROPS ISO 12117-2: 2008
FOPS Level 2
Noise-insulated and viscous mounted cab
Tinted safety glazing all around, full up and over windscreen
Sun blinds, large roof window, transparent rain protection
Automatic air conditioning
Rear View Camera with dedicated screen

OPTIONS

Hydraulic circuit for hammer / shears
Hydraulic circuit for grab rotation 22 l/min - ON/OFF control
Hydraulic circuit for grab rotation 80 l/min - PROPORTIONAL Control
Quick coupler provision on upperframe
Biodegradable hydraulic oil (Panolin)
Front Guard Protective system FGPS
20 km/h speed
35 km/h speed

Radio with Bluetooth
Control panel with LCD monitor integrating error diagnosis function and analogical gauges for engine cooling temperature and fuel level
Ergonomic design of arm rests and foot pedals
Air suspension seat individually adjustable for height and incline
Consoles adjustable for height and length
Forward/Reverse shifting on right joystick
Centralised and independent control of blade and stabilizers on right joystick
2 front headlights (cab mounted)
Road travel lights (front and rear)
Robust, shiled arc-welded, modular chassis in box section design
Power Shift gear box with manual / automatic gear shifting
Heavy duty axles with brakes for play-free work
Hydrostatic travel braking
Creeper speed
Large toolbox under the step (right side)
Encased ball bearing slew ring with long-life lubrication
Manual / automatic axle locking system
Electric diesel filling system
Safety valves on boom cylinders
Cylinders with end-stroke damping system
Long interval greasing bushings (500 hours)
Centralized greasing nipples on upperframe and boom
2 working lights on boom

Single or twin tyres
Dozer blade with parallel guidance
Heavy duty stabilizers with cylinder protection guards
Transport holder for clamshell grab
Blade cylinders protection guard
One piece boom, triple articulation (2 piece boom)
Arms: WX188: 2.20 - 2.60 - 3.10 m
WX218: 2.10 - 2.40 - 2.94 m
Object handling kit with safety valve on arm cylinder, overloading warning device and load hook or load eye.

Standard and optional equipment shown can vary by country.

WHEELED EXCAVATORS

WX188

SPECIFICATIONS

ENGINE

Net flywheel power (ISO 14396/ECE R120) _____ 118 kW / 158 hp
 Rated _____ 2000 rpm
 Make and model _____ F4GE9684E J607
 Type _____ Water-cooled, direct injection type diesel engine with intercooler turbo-charger
 Displacement _____ 6.7 l
 Number of cylinders _____ 6
 Bore x stroke _____ 104 x 132 mm
 Maximum torque at 1200 rpm _____ 670 Nm

ELECTRICAL SYSTEM

Voltage _____ 24 V
 Batteries _____ 2 x 12 V
 Battery rating (each) _____ 100 Ah
 Alternator _____ 70 A
 Starter motor _____ 4 kW

TRANSMISSION

| | km/h | km/h |
|------------------------------------|------|--------|
| Max Road travel speed | 20 | 35 |
| Max Field travel speed | 5 | 8 |
| Creep speed | 2.5 | 2.5 |
| Maximum drawbar pull (field) _____ | | 115 kN |

Power Shift multi-disc gearbox shifttable under load.
 Automatic or manual gear shift control.
 Travel mode automatically engaged by pressing accelerator pedal.

HYDRAULIC SYSTEM

2 x Primary pumps _____ 3 variable displacement, axial piston
 Total maximum flow _____ 389 l/min (2 x 144 + 101)
 Auxiliary low flow, optional (on/off) _____ 22 l/min
 Auxiliary medium flow, optional (proportional) _____ 80 l/min
 Implement/travel pressure _____ 340 / 370 bar
 PowerBoost _____ 370 bar
 Swing circuit pressure _____ 360 / 390 bar
 Pilot pump _____ 45 bar
 Boom cylinder mono _____ 115 x 1170 mm
 Boom cylinder 2-piece boom _____ 115 x 1020 mm
 Arm cylinder _____ 125 x 1290 mm
 Bucket cylinder _____ 105 x 1025 mm

Positioning cylinder _____ 155 x 745 mm
 Cylinder end stroke damping.
 Electrohydraulic servo-control.
 Three-pump hydraulics with two main pumps and separate swing pump. 8 selectable power stages with permanent Power Boost in lift stages: Low idle, Lift 1, Lift 2, Eco 1, Eco 2, Eco 3, Heavy, Roadtravel
 Adjustable swing acceleration (power) and deceleration (brake)
 Automatic power increase in the drive mode.

SWING DRIVE

Swing speed _____ 9 rpm
 Swing torque _____ 53 kNm
 The swing function is operated by a hydraulic closed circuit coupled with a mechanical reducer integrating an automatic static brake. The hydrostatic swing brake is adjustable in 3 settings.

BRAKES

Service brakes: play free, oil bath multi disc type integrated in all four wheel hubs.
 Work brake: acts on service brakes and locks front axle oscillation.
 Parking brake: spring type mechanical acting on the transmission.
 Emergency brake: double braking circuit and automatic parking and brake actuation with the engine shut down.

STEERING

Type _____ ORBITROL with safety valve
 Pump _____ gear type
 Steering cylinder _____ double effect, integrated in axle

TYRES

Twin tyres _____ 10.00-20/80-22.5
 Single tyres _____ 18R 19.5, 600/40-22.5
 Tyre availability can be limited by local homologation.

CAPACITIES

Engine oil _____ 15 l
 Cooling system _____ 22 l
 Fuel tank _____ 274 l
 Hydraulic system (incl. tank) _____ 235 l for mono
 _____ 250 l for triple articulation

GENERAL DIMENSIONS

WX188

Equipped with twin tires 10.00 - 20

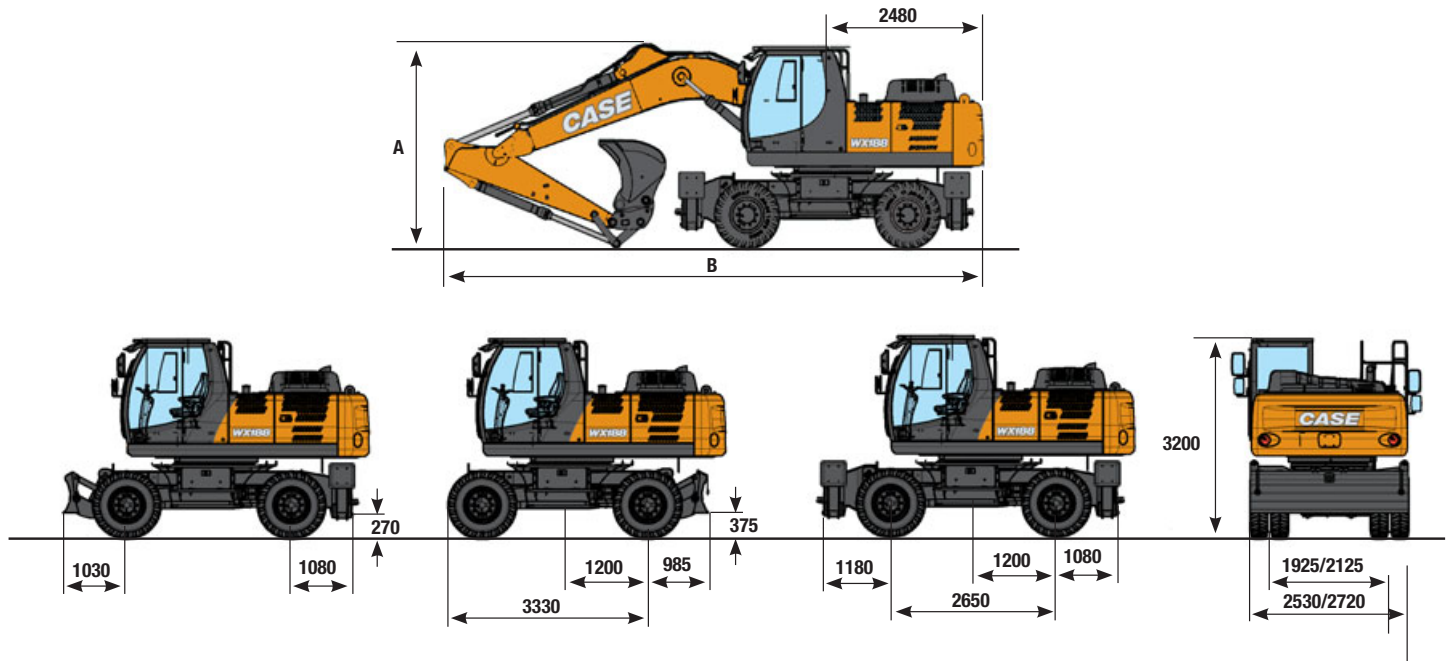

TRIPLE ARTICULATION 5.4 m

MONOBOOM 5.2 m

| | Arm 2.20 m | Arm 2.60 m | Arm 3.10 m | Arm 2.20 m | Arm 2.60 m | Arm 3.10 m |
|-------------------------|------------|------------|------------|------------|------------|------------|
| A | 2880 mm | 2830 mm | 3490 mm | 3120 mm | 3200 mm | 3800 mm |
| B with rear blade | 8920 mm | 8845 mm | 8835 mm | 8890 mm | 8810 mm | 8820 mm |
| B with rear stabilizers | 8920 mm | 8845 mm | 8835 mm | 8895 mm | 8810 mm | 8820 mm |

OPERATING WEIGHT WX188

2.55 axle width include bucket 610 kg and quick coupler 250 kg (with 10.00-20)

| | TRIPLE ARTICULATION | | | MONOBOOM | | |
|----------------------------|---------------------|------------|------------|------------|------------|------------|
| | Arm 2.20 m | Arm 2.60 m | Arm 3.10 m | Arm 2.20 m | Arm 2.60 m | Arm 3.10 m |
| Rear blade | 18550 kg | 18600 kg | 18700 kg | 18150 kg | 18200 kg | 18300 kg |
| Stabilizers | 18950 kg | 19000 kg | 19100 kg | 18550 kg | 18600 kg | 18700 kg |
| Blade and stabilizers | 19500 kg | 19550 kg | 19650 kg | 19150 kg | 19200 kg | 19300 kg |
| Stabilizers rear and front | 20000 kg | 20050 kg | 20150 kg | 19650 kg | 19700 kg | 19800 kg |

2.75 axle width include bucket 610 kg and quick coupler 250 kg (with 11.00-20)

| | TRIPLE ARTICULATION | | | MONOBOOM | | |
|----------------------------|---------------------|------------|------------|------------|------------|------------|
| | Arm 2.20 m | Arm 2.60 m | Arm 3.10 m | Arm 2.20 m | Arm 2.60 m | Arm 3.10 m |
| Rear blade | 18650 kg | 18700 kg | 18800 kg | 18250 kg | 18300 kg | 18400 kg |
| Stabilizers | 19050 kg | 19100 kg | 19200 kg | 18650 kg | 18700 kg | 18800 kg |
| Blade and stabilizers | 19650 kg | 19700 kg | 19800 kg | 19250 kg | 19300 kg | 19400 kg |
| Stabilizers rear and front | 20100 kg | 20150 kg | 20250 kg | 19750 kg | 19800 kg | 19900 kg |

PERFORMANCE DATA

WX188

TRIPLE ARTICULATION

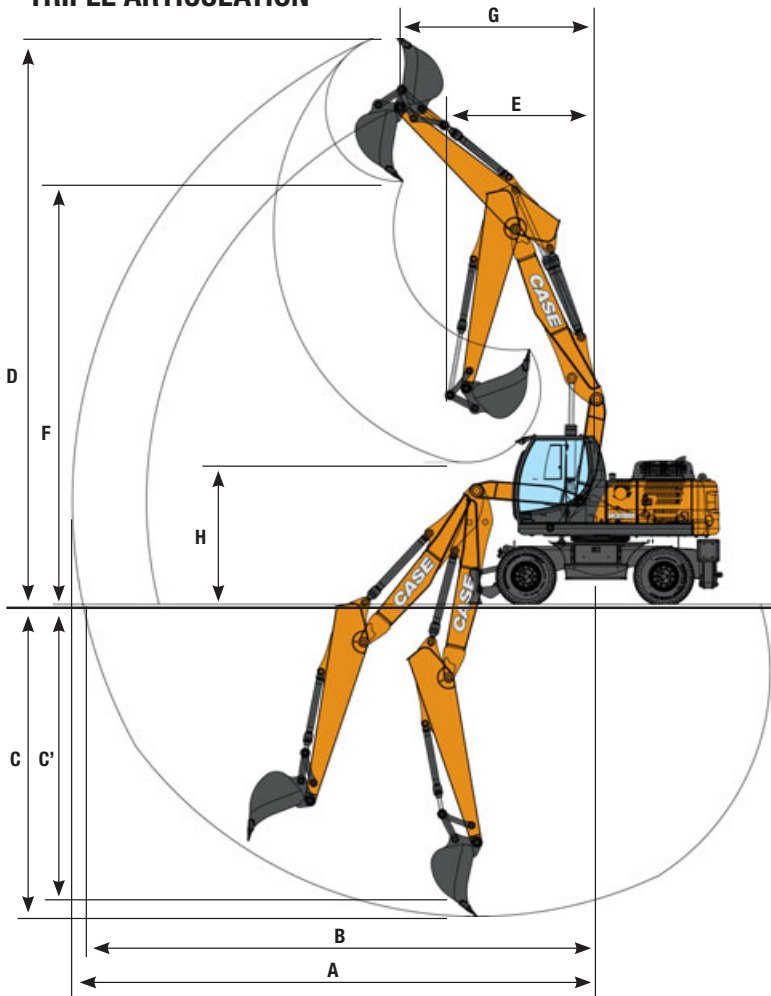

MONOBOOM

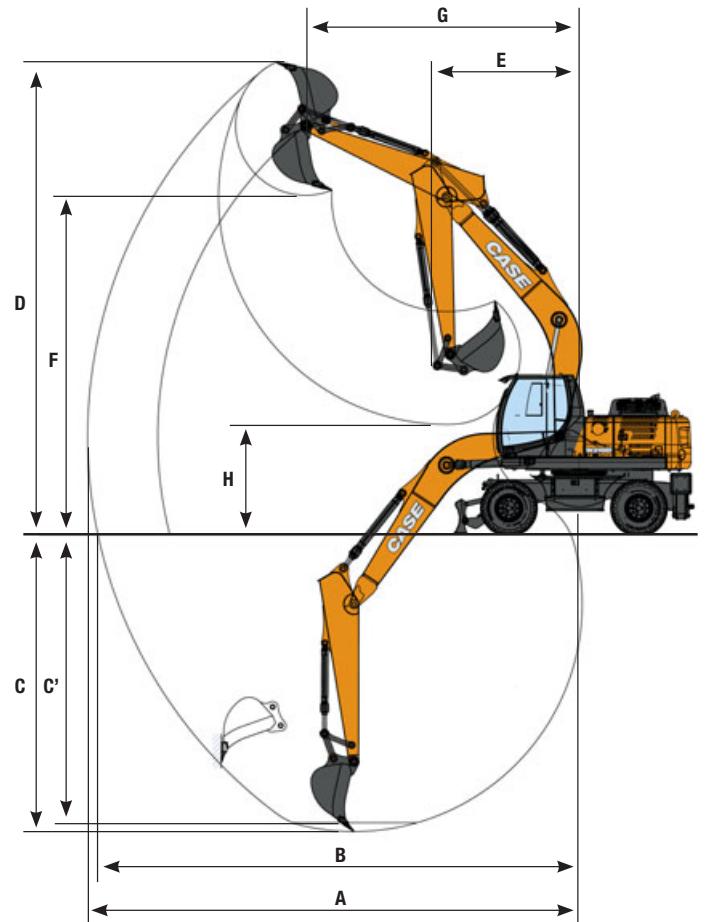

| | TRIPLE ARTICULATION | | | MONOBOOM | | |
|--|---------------------|------------|------------|------------|------------|------------|
| | Arm 2.20 m | Arm 2.60 m | Arm 3.10 m | Arm 2.20 m | Arm 2.60 m | Arm 3.10 m |
| A Max. digging reach | 9000 mm | 9400 mm | 9900 mm | 8900 mm | 9300 mm | 9800 mm |
| B Max. digging reach at ground level | 8800 mm | 9200 mm | 9700 mm | 8700 mm | 9100 mm | 9600 mm |
| C Max. digging depth | 4900 mm | 5300 mm | 5800 mm | 4900 mm | 5300 mm | 5800 mm |
| C' Max. depth of cut for 8' level bottom | 4800 mm | 5200 mm | 5700 mm | 4700 mm | 5100 mm | 5700 mm |
| D Max. digging height | 10100 mm | 10300 mm | 10800 mm | 9200 mm | 9300 mm | 9600 mm |
| E Min. front swing radius | 3050 mm | 2800 mm | 2900 mm | 3400 mm | 3300 mm | 3300 mm |
| F Max. loading height | 7400 mm | 7600 mm | 8000 mm | 6500 mm | 6600 mm | 7000 mm |
| G Front swing radius at max height | 2900 mm | 3200 mm | 3500 mm | 4400 mm | 4800 mm | 5200 mm |
| H Max. loading height (arm retracted) | 3700 mm | 3100 mm | 2600 mm | 3100 mm | 2700 mm | 2200 mm |

DIGGING FORCE - ISO WX188

| | Arm 2.20 m | Arm 2.60 m | Arm 3.10 m |
|-------------------------|------------|------------|------------|
| Arm digging force | 98 kN | 84 kN | 73 kN |
| - with auto power boost | 107 kN | 91 kN | 79 kN |
| Bucket digging force | 125 kN | 125 kN | 125 kN |
| - with auto power boost | 136 kN | 136 kN | 136 kN |

WHEELED EXCAVATORS

WX218

SPECIFICATIONS

ENGINE

Net flywheel power (ISO 14396/ECE R120) _____ 129 kW / 173 hp
 Rated _____ 2000 rpm
 Make and model _____ F4GE9684G J666
 Type _____ Water-cooled, 6 cylinder direct injection
 type diesel engine with intercooler turbo-charger
 Displacement _____ 6.728 l
 Number of cylinders _____ 6
 Bore x stroke _____ 104 x 132 mm
 Maximum torque at 1200 rpm _____ 745 Nm

ELECTRICAL SYSTEM

Voltage _____ 24 V
 Batteries _____ 2 x 12 V
 Battery rating (each) _____ 100 Ah
 Alternator _____ 70 A
 Starter motor _____ 4 kW

TRANSMISSION

| | km/h | km/h |
|------------------------|------|------|
| Max Road travel speed | 20 | 35 |
| Max Field travel speed | 5 | 9 |
| Creep speed | 2.9 | 2.9 |

Maximum drawbar pull _____ 121 kN
 Power shift multi-disc gearbox shiftable under load
 Automatic or manual gear shift control.
 Travel mode automatically engaged by pressing accelerator pedal.

HYDRAULIC SYSTEM

2 x Primary pumps _____ 3 variable displacement, axial piston
 Total maximum flow _____ 512 l/min (2 x 203 + 106)
 Auxiliary low flow, optional (on/off) _____ 22 l/min
 Auxiliary medium flow, optional (proportional) _____ 80 l/min
 Implement/travel pressure _____ 340 / 370 bar
 PowerBoost _____ 370 bar
 Swing circuit pressure _____ 360 / 390 bar
 Pilot pump _____ 45 bar
 Boom cylinder mono _____ 120 x 1290 mm
 Boom cylinder 2-piece boom _____ 120 x 990 mm
 Arm cylinder _____ 135 x 1560 mm
 Bucket cylinder _____ 120 x 1080 mm

Positioning cylinder _____ 170 x 640 mm
 Cylinder end stroke damping.
 Electrohydraulic servo-control.
 Three-pump hydraulics with two main pumps and separate swing pump. 8 selectable power stages with permanent Power Boost in lift stages: Low idle, Lift 1, Lift 2, Eco 1, Eco 2, Eco 3, Heavy, Roadtravel
 Adjustable swing acceleration (power) and deceleration (brake)
 Automatic power increase in the drive mode.

SWING DRIVE

Swing speed _____ 9 rpm
 Swing torque _____ 58 kNm
 The swing function is operated by a hydraulic closed circuit coupled with a mechanical reducer integrating an automatic static brake. The hydrostatic swing brake is adjustable in 3 settings.

BRAKES

Service brakes: Play free, oil bath multi disc type integrated operating at 75 bar.
 Work brake: Acts on service brakes and locks front axle oscillation.
 Parking brake: Spring type mechanical action on the transmission in all four wheel hubs
 Emergency brake: Double braking circuit and automatic parking and brake actuation with the engine shut down

STEERING

Type _____ ORBITROL with safety valve
 Pump _____ gear type
 Steering cylinder _____ double effect, integrated in axle

TYRES

Twin tyres _____ 10.00-20/11.00-20
 Single tyres _____ 18 -22.5/600-40-22.5/620-40-22.5
 Tyre availability can be limited by local homologation.

CAPACITIES

Engine oil _____ 8/15 l
 Cooling system _____ 11 l
 Fuel tank _____ 296 l
 Hydraulic system (incl. tank) _____ 270 l for mono
 _____ 290 l for triple articulation

GENERAL DIMENSIONS

WX218

equipped with twin tires 11.00 - 20

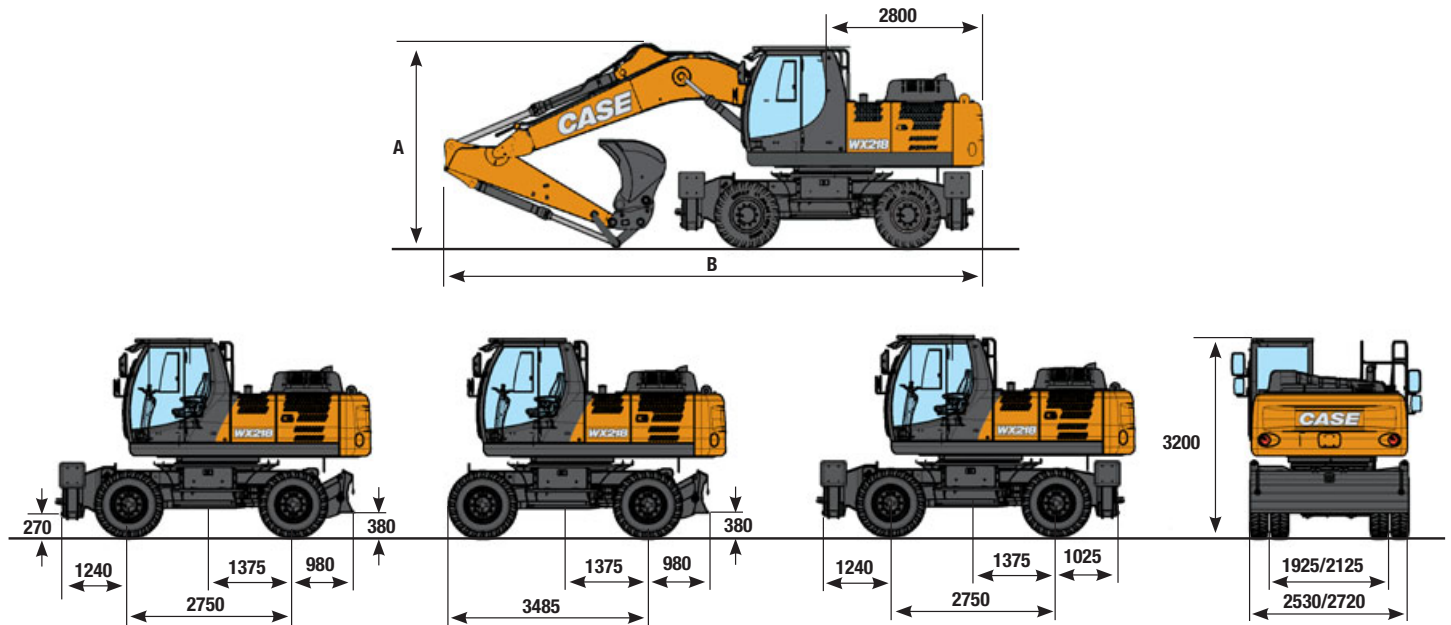

| | TRIPLE ARTICULATION 5.5 m | | | MONOBOOM 5.6 m | | |
|-------------------------|---------------------------|------------|------------|----------------|------------|------------|
| | Arm 2.10 m | Arm 2.40 m | Arm 2.94 m | Arm 2.10 m | Arm 2.40 m | Arm 2.94 m |
| A | 2970 mm | 2985 mm | 3115 mm | 3345 mm | 3270 mm | 3225 mm |
| B with rear blade | 9385 mm | 9355 mm | 9360 mm | 9765 mm | 9730 mm | 9655 mm |
| B with rear stabilizers | 9385 mm | 9355 mm | 9360 mm | 9765 mm | 9730 mm | 9700 mm |

OPERATING WEIGHT WX218

2.55 axle width include bucket 800 kg and quick coupler 250 kg (with 11.00-20)

| | TRIPLE ARTICULATION | | | MONOBOOM | | |
|----------------------------|---------------------|------------|------------|------------|------------|------------|
| | Arm 2.10 m | Arm 2.40 m | Arm 2.94 m | Arm 2.10 m | Arm 2.40 m | Arm 2.94 m |
| Rear blade | 20300 kg | 20300 kg | 20400 kg | 19950 kg | 19950 kg | 20050 kg |
| Stabilizers | 20600 kg | 20600 kg | 20700 kg | 20350 kg | 20350 kg | 20450 kg |
| Rear Blade and stabilizers | 21200 kg | 21200 kg | 21300 kg | 20950 kg | 20950 kg | 21050 kg |
| Stabilizers rear and front | 21450 kg | 21450 kg | 21550 kg | 21200 kg | 21200 kg | 21300 kg |

2.75 axle width include bucket 800 kg and quick coupler 250 kg (with 11.00-20)

| | TRIPLE ARTICULATION | | | MONOBOOM | | |
|----------------------------|---------------------|------------|------------|------------|------------|------------|
| | Arm 2.10 m | Arm 2.40 m | Arm 2.94 m | Arm 2.10 m | Arm 2.40 m | Arm 2.94 m |
| Rear blade | 20400 kg | 20400 kg | 20500 kg | 20050 kg | 20050 kg | 20150 kg |
| Stabilizers | 20700 kg | 20700 kg | 20800 kg | 20450 kg | 20450 kg | 20550 kg |
| Rear Blade and stabilizers | 21300 kg | 21300 kg | 21400 kg | 21050 kg | 21050 kg | 21150 kg |
| Stabilizers rear and front | 21550 kg | 21550 kg | 21650 kg | 21300 kg | 21300 kg | 21400 kg |

PERFORMANCE DATA

WX218

TRIPLE ARTICULATION

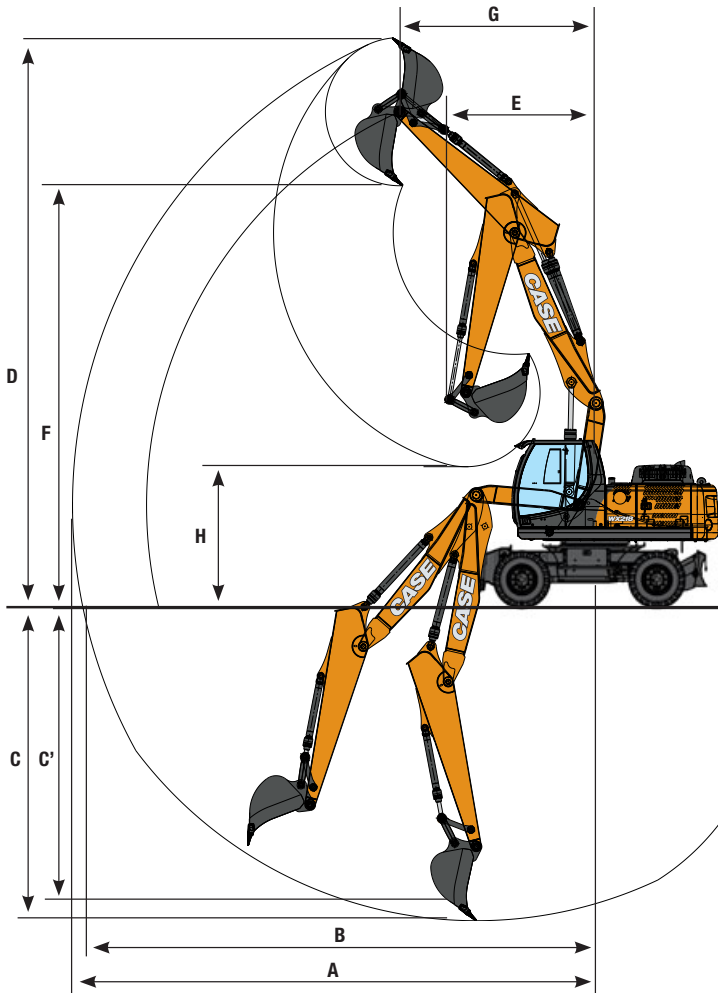

MONOBOOM

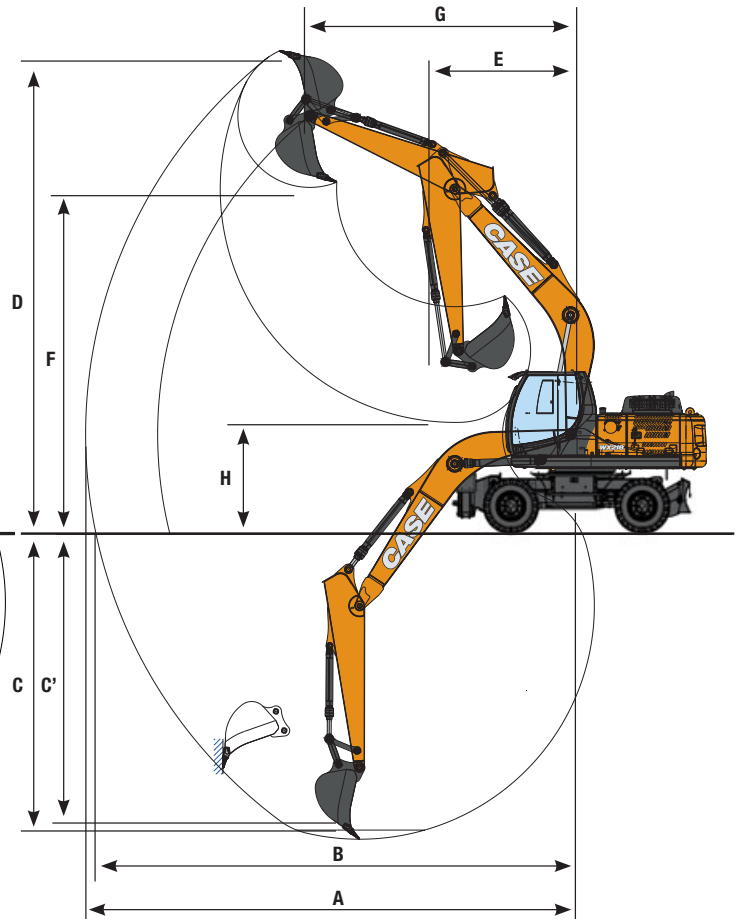

| | TRIPLE ARTICULATION | | | MONOBOOM | | |
|--|---------------------|------------|------------|------------|------------|------------|
| | Arm 2.10 m | Arm 2.40 m | Arm 2.94 m | Arm 2.10 m | Arm 2.40 m | Arm 2.94 m |
| A Max. digging reach | 8980 mm | 9270 mm | 9770 mm | 9270 mm | 9530 mm | 10010 mm |
| B Max. digging reach at ground level | 8770 mm | 9050 mm | 9570 mm | 9050 mm | 9320 mm | 9820 mm |
| C Max. digging depth | 4850 mm | 5160 mm | 5690 mm | 4940 mm | 5260 mm | 5800 mm |
| C' Max. depth of cut for 8' level bottom | 4740 mm | 5060 mm | 5590 mm | 4720 mm | 5060 mm | 5630 mm |
| D Max. digging height | 10050 mm | 10230 mm | 10590 mm | 10200 mm | 10340 mm | 10650 mm |
| E Min. front swing radius | 3370 mm | 3100 mm | 2800 mm | 3240 mm | 2940 mm | 2790 mm |
| F Max. loading height | 7260 mm | 7440 mm | 7800 mm | 7470 mm | 7580 mm | 7890 mm |
| G Front swing radius at max height | 3130 mm | 3420 mm | 3830 mm | 3430 mm | 3740 mm | 4190 mm |
| H Max. loading height (arm retracted) | 3790 mm | 3320 mm | 2680 mm | 4010 mm | 3580 mm | 2990 mm |

DIGGING FORCE - ISO WX218

| | Arm 2.20 m | Arm 2.60 m | Arm 3.10 m |
|-------------------------|------------|------------|------------|
| Arm digging force | 140 kN | 122 kN | 102 kN |
| - with auto power boost | 152 kN | 133 kN | 111 kN |
| Bucket digging force | 156 kN | 156 kN | 156 kN |
| - with auto power boost | 169 kN | 170 kN | 170 kN |

www.casece.com

EXPERTS FOR THE REAL WORLD
SINCE 1842

CASE
CONSTRUCTION



Form No. 20071GB - Printed in Italy - MediaCross Firenze - 01/17

**CNH INDUSTRIAL
DEUTSCHLAND GMBH**
Case Baumaschinen
Benzstr. 1-3 - D-74076 Heilbronn
DEUTSCHLAND

CNH INDUSTRIAL FRANCE, S.A.
16-18 Rue des Rochettes
91150 Morigny-Champigny
FRANCE

CNH INDUSTRIAL - UK
First Floor, Barclay Court 2,
Heavens Walk,
Doncaster - DN4 5HZ
UNITED KINGDOM

CNH INDUSTRIAL - SOUTH AFRICA
Waterfall Business Park
Bekker Street, Howick Close
1685 Midrand - Johannesburg
REPUBLIC OF SOUTH AFRICA

**CNH INDUSTRIAL
MAQUINARIA SPAIN, S.A.**
Avda. José Gárate, 11
28823 Coslada (Madrid)
ESPAÑA

CNH INDUSTRIAL ITALIA SPA
Strada di Settimo, 323
10099 San Mauro Torinese (TO)
ITALIA

**CASE CUSTOMER CENTRE
PARIS**
RN 330 - Penchard
77122 - Monthyon
FRANCE

CNH INDUSTRIAL - MIDDLE EAST
DAFZA - Dubai Airport Free Zone
West Wing 4 B, Office 642
P.O. Box 54588, Dubai,
UNITED ARAB EMIRATES

NOTE: Standard and optional fittings can vary according to the demands and specific regulations of each country. The illustrations may include optional rather than standard fittings - consult your Case dealer. Furthermore, CNH Industrial reserves the right to modify machine specifications without incurring any obligation relating to such changes.

Conforms to directive 2006/42/EC

CASE
00800-2273-7373

The call is free from a land line.
Check in advance with your Mobile Operator if you will be charged. Toll free number not available from all calling areas.

