



Bracke P11.a Planter

The Bracke P11.a makes it possible to conduct the full scope of regeneration work from scarification to planting with a single machine. The Bracke P11.a provides regeneration of the highest quality with the greatest possible consideration for environmental and ecological aspects.

Function

Normally, the Bracke P11.a makes a mound of inverted humus, compacts it and sets the plants in the middle of the mound. Mounding is the preferred planting method for most soil types. It is even possible to vary the scarification by raking the ground with the head's bucket, to make scarification patches, or to plant directly without scarification. All functions are easily controlled from the cab. Whatever the scarification method, the operator can make allowances for naturally regenerating plants and ecological conditions, as well as cultural aspects and relics.

Machine control

Bracke Growth Control, the control system, is based on a PLC platform and communicates over a CAN bus. The head is fitted with sensors that send information to Bracke Growth Control about, for example, the planting tube's position. Adjustment and reading of the planting depth, compaction and other variables is done over the display in the cab and all units in the control system can communicate over the CAN bus. Bracke Growth Control keeps track of the number of plants set in the ground, for both individual sites and in total, and the number of hours worked. The planting and mounding function are controlled effortlessly with two control buttons over the control system.

Targeted planting

The Bracke P11.a delivers effective scarification and planting on all types of soil, from easily worked and fertile ground to stony fields covered in slash. The operator can choose the planting spot for each individual plant and even decide how the planting spots are formed.

Bracke reserves the right to make changes. 2017-05-10

Technical data

Prime mover	Excavator 14 – 20 ton
Weight	1 100 kg
Hydraulic pressure	125 bar
Hydraulic flow	min 100 l/min
Plant type	Covered root plants
Plant magazine & plant pipe	Standard 60 mm (72 plants)
Option	50 mm magazine (88 plants)
Option	70 mm (62 plants)
Bucket	Standard 600 mm Option 500 mm
Electrical system	24 V
Control system	
Bracke Growth Control	PLC based
Productivity per hour	Up to 300 plants
Accessories	Equipment for additives



Bracke Growth Control is a PLC-based control system.

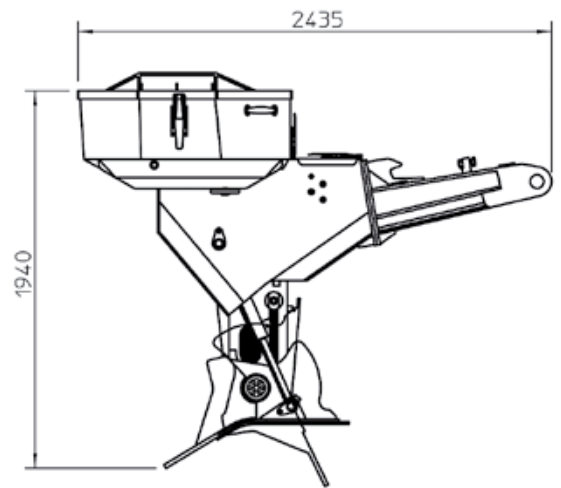
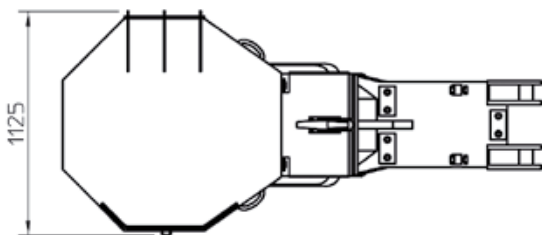

The P11.a provides regeneration of the highest quality and with the greatest possible consideration for biological aspects.



The P11.a both scarifies and plants.



The P11.a plants at the same depth in the center of each mound every time for the best production and survival.